

Optical A/B Switch

OS-3121

For Secure Fiber Optic Signal Selection Applications

The OS-3121 is a fiber optic switch that can be controlled remotely or through a front panel switch. The optical path through the units is purely mechanical. There is no optical to electrical to optical conversion. As a result, there is no data rate limitation or bandwidth limit on the fiber optic path. In addition, since the optical signal is not demodulated the optical data is totally secure. The optical path can be select via a front panel switch or via contact closure input. In event of loss of power, the unit has a fail safe mode that opens the switch.

Common applications for this device are optical routing, system bypass, network cut off switch, and fiber optic testing. The OS-3121 control can be daisy chained to switch multiple optical connections. For two OS-3121 mounted in a single housing, order the OS-3221.



Technical Specifications

| | |
|-----------------------|---------------------------------------|
| Switching Time | < 10 ms |
| Back Reflection | < -50 dB |
| Insertion Loss | < 1.3 dB |
| Cross Talk | < -50 dB |
| Switch Life cycle | > 1 Million cycles |
| Operating Wavelength | 850/1310 or 1310/1550nm |
| Optical Connectors | ST, SC, or FCPC |
| Operating Temperature | 0° to +70°C |
| Power Requirements* | 11-24 VAC/DC @150 mA |
| Size (mm) Single | 5.0" (127) x 3.0" (76) x 1.0" (25.4) |
| Size (mm) Dual | 5.0" (127) x 3.0" (76) x 2.23" (56.6) |

* -48VDC only models available by request.
Note that all specifications are subject to change without prior notice.

Important Features

- **Switching time < 10 ms**
- **Fail-safe return to bypass mode with loss of power**
- **Small physical footprint**
- **Multimode or single-mode versions**
- **Stand-alone, DIN or Rack Mountable (same unit)**
- **Power and Switch status indicators**

Ordering Information; OS-3121-X where "X" = Wavelength/Fiber/Connector
-3 = 850/1310nm Multi-mode ST/PC -4 = 850/1310nm Multi-mode- SC/PC
-5 = 1310/1550nm Single-mode SC/PC -7 = 1310/1550nm Single-mode FC/PC

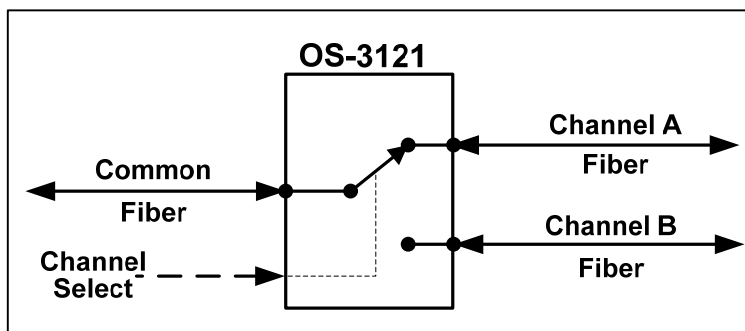

LuxLink[®]
Fiber Optic Transmission Systems

www.LuxLink.com
USA 516-931-2800